

HYDRONIC AIR HANDLER CABINET CENTRAL BOILER

The Heating air handler Cabinet includes: the coil, the housing, the direct drive squirrel cage and the filter compartment. It is specially designed to be used with ductwork that carries heat to different rooms in the building.

Direct Drive hydronic heater cabinet (air handler cabinet)						
Model	Btu Max	FNPT	Motor	Width mm (po)	Length mm (po)	Height mm (po)
ZTJ-301-100	100 000	3/4"	1/4 HP	508 (20")	584 (23")	915 (36")
ZTJ-301-125	125 000	3/4"	1/4 HP	508 (20")	584 (23")	915 (36")
ZTJ-301-140	140 000	3/4"	1/4 HP	508 (20")	584 (23")	915 (36")
ZTJ-303-185	185 000	3/4"	1 HP	635 (25")	711 (28")	991 (39")
ZTJ-303-220	220 000	3/4"	1 HP	635 (25")	711 (28")	991 (39")
3-speed direct drive motor						
NOT ASSEMBLED, for having it assembled (added A to the code ex: ZTJ-301-100A)						

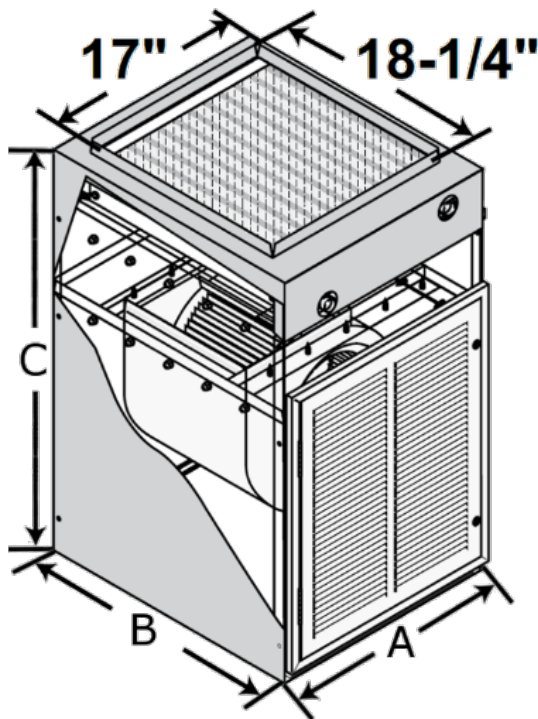

TJ-154 1/4 hp 115V	CFM (cubic feet per minute)				
	FREE AIR	1/4"SP	1/2"SP	3/4"SP	1" SP
Vitesse LOW	708	808	800	593	194
Vitesse MED	963	1063	1020	708	224
Vitesse HIGH	1353	1349	1287	1014	250
SP=static pressure, hp=horsepower					

TJ-208 1 hp 115V	CFM (cubic feet per minute)					
	1.2"SP	1.3"SP	1.4"SP	1.5"SP	1.6"SP	1.7"SP
Vitesse LOW (1038 rpm)	2248	2143	2032	1890	1085	1498
Vitesse MED (1070 rpm)	2480	2373	2218	2084	1910	1696
Vitesse HIGH (1097 rpm)	2701	2522	2373	2231	2057	1851
SP=static pressure, hp=horsepower						